

REV.	DESCRIPTION	DATE	BY

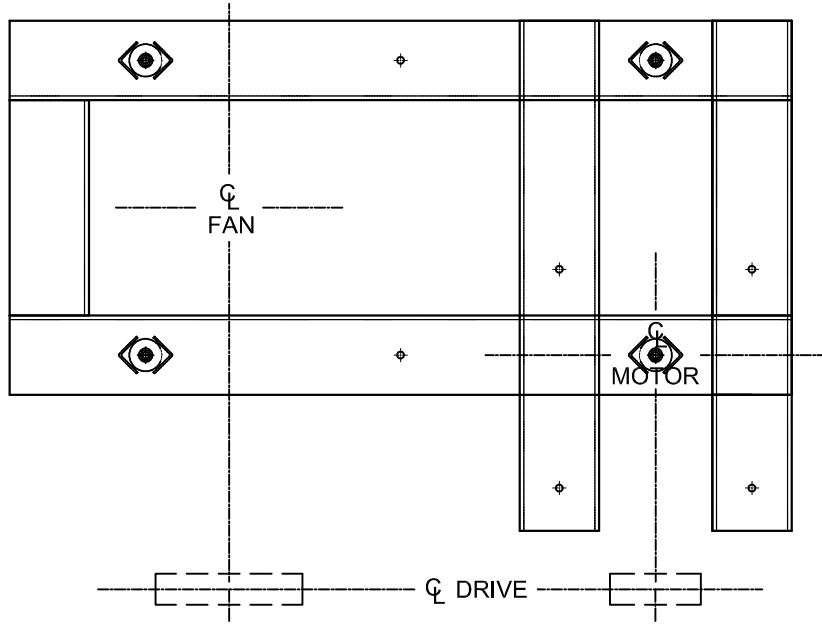

NOTE:
 STEEL MEMBERS ARE STANDARD AISC STRUCTURAL SECTIONS SIZED TO PROPERLY SUPPORT LOAD AND TO LIMIT STEEL BEAM DEFLECTION TO 0.05" MAXIMUM DUE TO BELT PULL AND STARTING TORQUE.

WHEEL DIAMETERS 12-1/4" TO 36-1/2" ANGLE CONSTRUCTION
 40-1/4" TO 54-1/4" ANGLE OR WIDE FLANGE CONSTRUCTION 60"
 AND LARGER WF AND CHANNEL CONSTRUCTION.

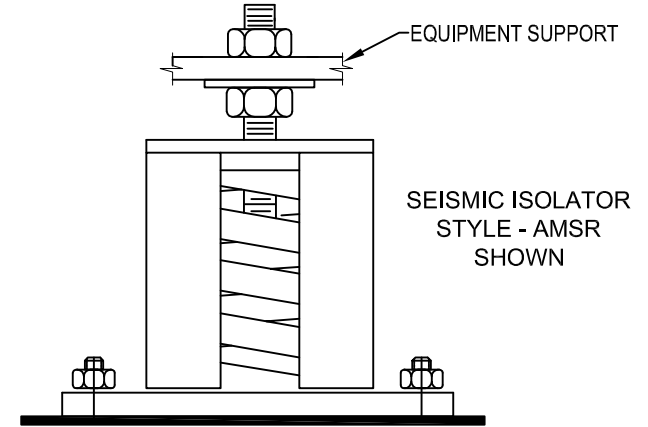

BRACKETS NOT REQUIRED FOR ANGLE CONSTRUCTION.
 WF BASES FURNISHED WITH HEIGHT-SAVING BRACKETS.

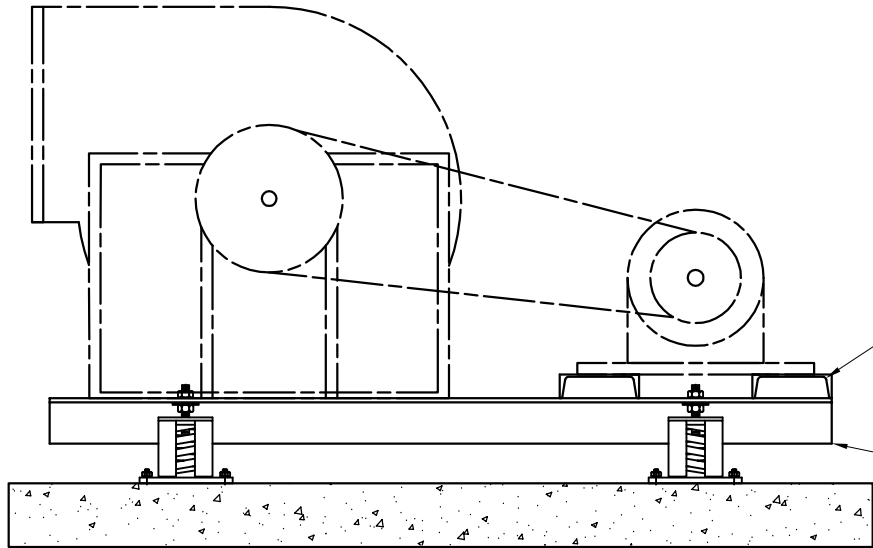

OTHER MATERIALS, COMPOUNDS, OR FINISHES WITH EQUAL OR SUPERIOR PROPERTIES MAY BE SUBSTITUTED AS THEY BECOME AVAILABLE.

CERTIFIED FOR:

JOB NAME: _____
 CUSTOMER : _____
 CUSTOMER P.O.: _____
 SALES ORDER: _____

**MODEL SFB INTEGRAL STEEL FAN AND
 MOTOR BASE 3 INCH DEFLECTION
 WITH SEISMIC ISOLATORS**



THE VMC GROUP
The Power of Together
 Bloomingdale, NJ 07403
 Houston, TX 77041

SCALE :
 NONE
 SHEET:
 1 OF 1



DRAWING NO.: _____ REVISION